

# Pecco SK 280-16

## TOWER CRANE

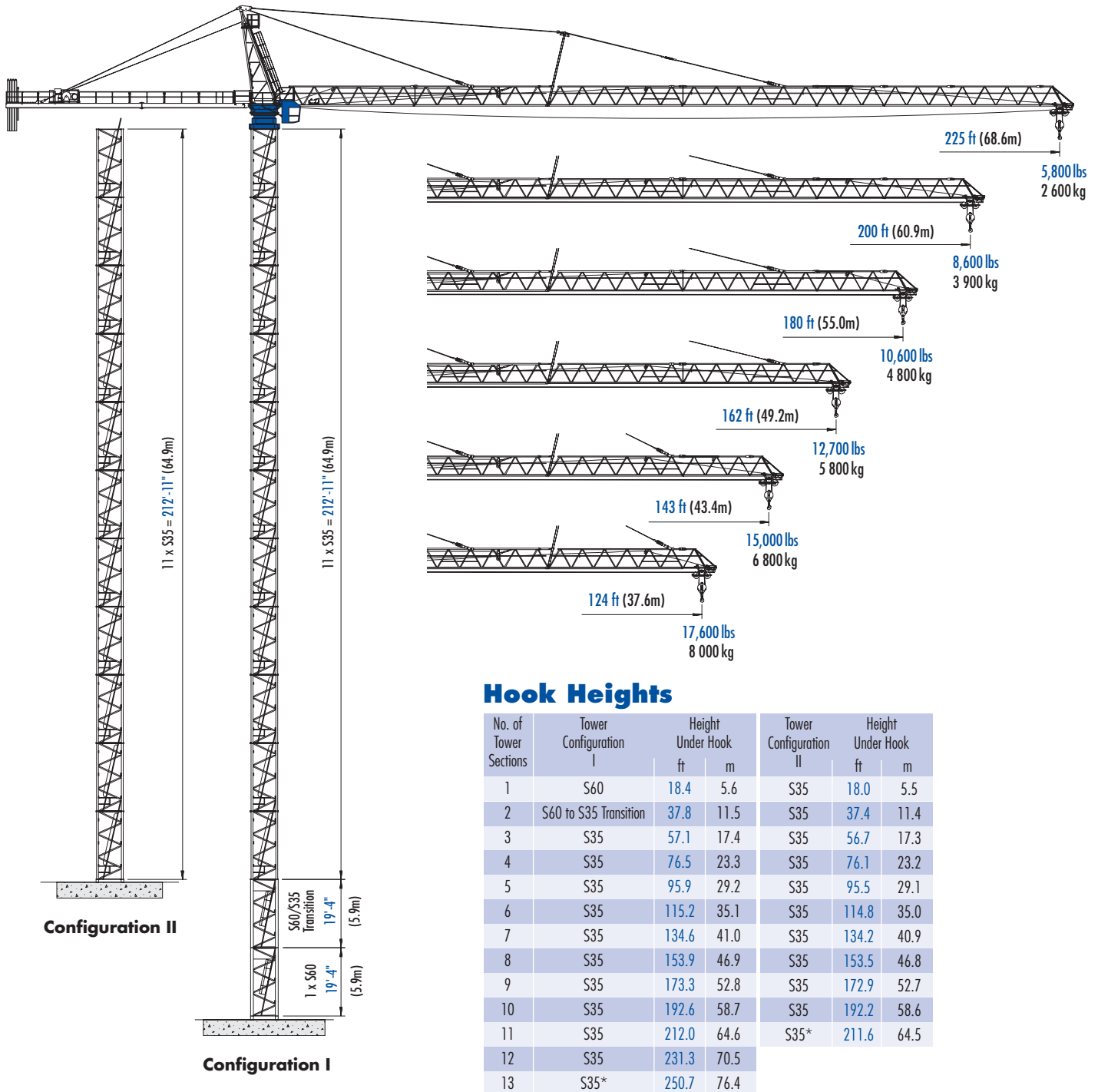

### FREESTANDING

(stationary)

\* Lower the top climbing unit to base of crane prior to operating crane at maximum hook height.

Other tower combinations are possible. Contact Morrow Equipment for additional information.



# Morrow Equipment

# Configurations

# Pecco SK 280-16

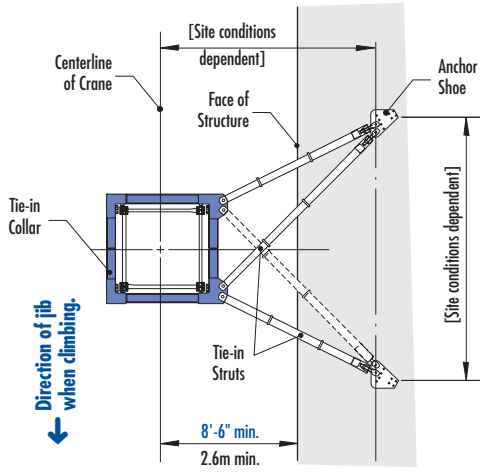

**TIE-IN ASSEMBLY**  
(Plan View)

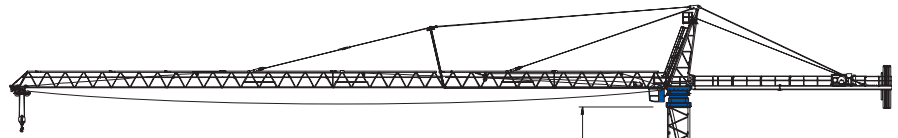

**NOTE!** If hook height exceeds 330 ft (100m), the number of tower sections above the uppermost tie-in location **MUST** be reduced by 1 tower section.

\* Lower the top climbing unit to the uppermost tie-in prior to operating crane at maximum hook height.

Consult Morrow for specific information regarding alternate foundation details, dimensions, tie-in locations, reaction forces and slab openings.

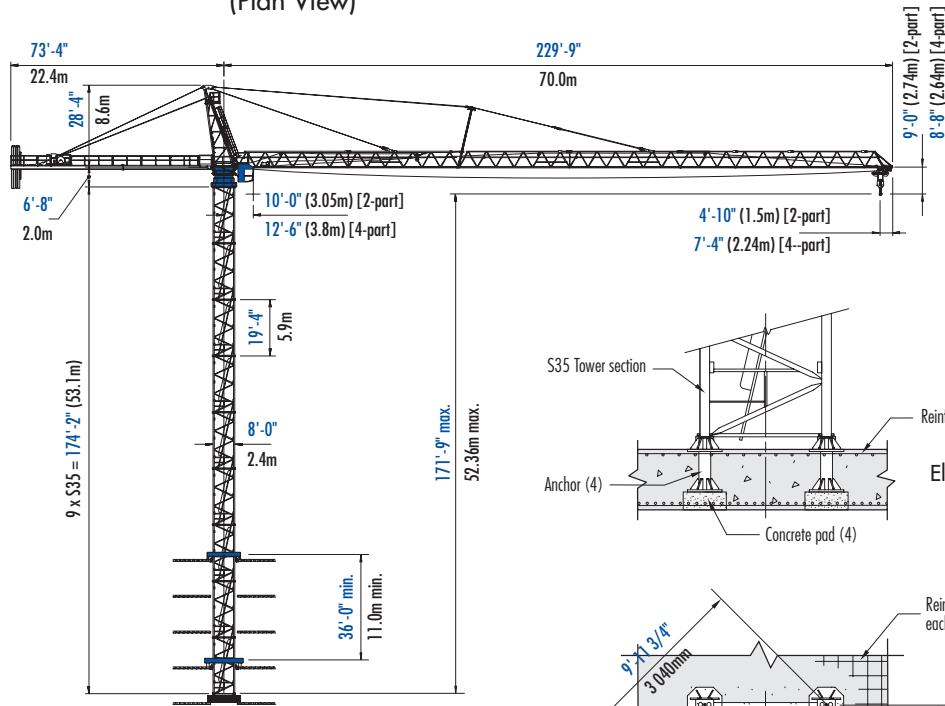

**BOTTOM CLIMBING**  
with S35 Tower Sections  
(Inside Structure)

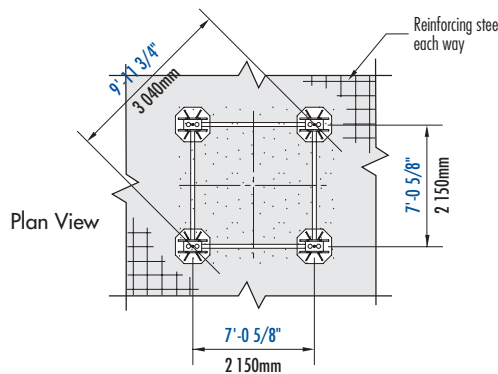
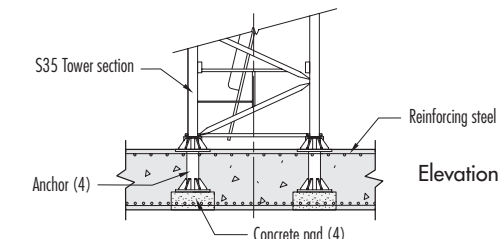

**FOUNDATION DETAILS**  
with S35 Tower Sections  
(Concrete Slab)

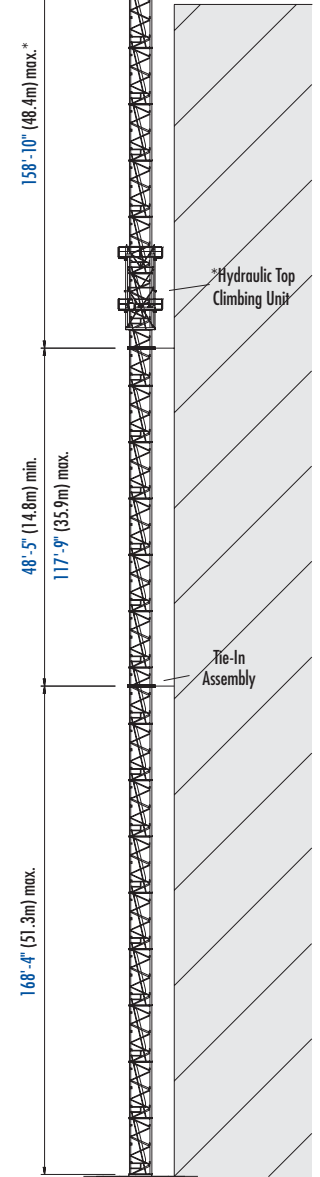

**TOP CLIMBING**  
with S35 Tower Sections  
(Tied to Structure)

**IMPORTANT!** Please consult crane's operation manual before erecting, operating and dismantling crane.

# Radius and Capacities

## Pecco Tower Crane Model SK 280-16

### 2-Part Line

Hook Radius	2-Part Line Max Capacity – Radius	ft m	88	105	109	117	121	124	130	140	143	150	162	170	180	190	200	210	225
			26.8	32.0	33.2	35.7	36.9	37.6	39.6	42.7	43.4	45.7	49.2	51.8	55.0	57.9	60.9	64.0	68.6
225 ft 68.6m	17,600 lbs – 88 ft 8 000 kg – 26.8m	lbs kg	17,600 8 000	14,500 6 580	13,700 6 210	12,800 5 810	12,300 5 580	12,000 5 440	11,300 5 130	10,400 4 720	10,200 4 630	9,500 4 310	8,700 3 950	8,200 3 720	7,500 3 400	7,100 3 220	6,700 3 040	6,300 2 860	5,800 2 600
200 ft 60.9m	17,600 lbs – 109 ft 8 000 kg – 33.2m	lbs kg	17,600 8 000	17,600 8 000	17,600 8 000	16,000 7 260	15,500 7 030	15,100 6 850	14,200 6 440	13,100 5 940	12,800 5 810	12,000 5 440	11,000 4 900	10,400 4 720	9,700 4 400	9,000 4 080	8,600 3 900		
180 ft 55.0m	17,600 lbs – 117 ft 8 000 kg – 35.7m	lbs kg	17,600 8 000	17,600 8 000	17,600 8 000	17,600 8 000	16,700 7 580	16,300 7 390	15,300 6 940	14,100 6 400	13,800 6 260	13,000 5 900	12,000 5 440	11,300 5 130	10,600 4 800				
162 ft 49.2m	17,600 lbs – 121 ft 8 000 kg – 36.9m	lbs kg	17,600 8 000	17,600 8 000	17,600 8 000	17,600 8 000	17,600 8 000	17,100 7 760	16,200 7 350	14,800 6 710	14,600 6 620	13,700 6 210	12,700 5 800						
143 ft 43.4m	17,600 lbs – 124 ft 8 000 kg – 37.6m	lbs kg	17,600 8 000	17,600 8 000	17,600 8 000	17,600 8 000	17,600 8 000	17,600 8 000	16,600 7 530	15,300 6 940	15,000 6 800								
124 ft 37.6m	17,600 lbs – 124 ft 8 000 kg – 37.6m	lbs kg	17,600 8 000	17,600 8 000	17,600 8 000	17,600 8 000	17,600 8 000	17,600 8 000											

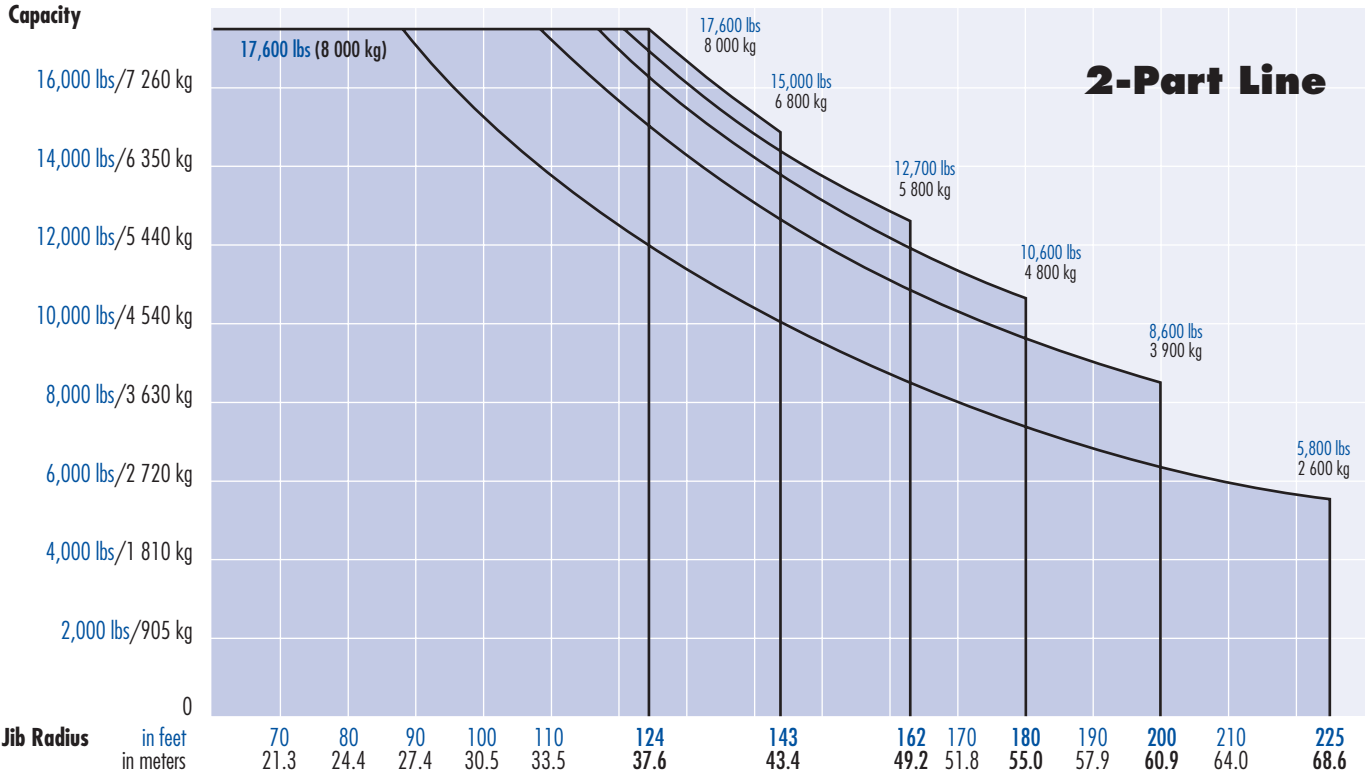

# Radius and Capacities

## Pecco Tower Crane Model SK 280-16

### 4-Part Line

Hook Radius	4-Part Line Max Capacity – Radius	ft m	60	70	80	90	100	110	121	130	140	150	159	170	178	190	197	210	223
			18.3	21.3	24.4	27.4	30.5	33.5	36.9	39.6	42.7	45.7	48.5	51.8	54.3	57.9	60.0	64.0	68.0
223 ft 68.0m	35,200 lbs – 46 ft 16 000 kg – 14.0m	lbs kg	25,500 11 570	21,200 9 620	18,000 8 160	15,600 7 080	13,600 6 170	12,000 5 440	10,600 4 810	9,700 4 400	8,800 3 990	8,000 3 630	7,400 3 360	6,700 3 040	6,200 2 810	5,600 2 540	5,300 2 400	4,800 2 180	4,400 2 000
197 ft 60.0m	35,200 lbs – 56 ft 16 000 kg – 17.1m	lbs kg	32,200 14 610	26,800 12 160	23,000 10 430	20,000 9 070	17,600 7 980	15,700 7 120	13,900 6 310	12,800 5 810	11,600 5 260	10,600 4 810	9,800 4 450	9,000 4 080	8,400 3 810	7,600 3 450	7,200 3 300		
178 ft 54.3m	35,200 lbs – 59 ft 16 000 kg – 18.0m	lbs kg	35,200 16 000	29,100 13 200	25,000 11 340	21,800 9 890	19,200 8 710	17,100 7 760	15,200 6 890	13,900 6 310	12,600 5 720	11,500 5 220	10,600 4 810	9,700 4 400	9,100 4 100				
159 ft 48.5m	35,200 lbs – 62 ft 16 000 kg – 18.9m	lbs kg	35,200 16 000	30,300 13 740	26,000 11 790	22,600 10 250	20,000 9 070	17,800 8 070	15,800 7 170	14,600 6 620	13,300 6 030	12,200 5 530	11,300 5 100						
140 ft 42.7m	35,200 lbs – 63 ft 16 000 kg – 19.2m	lbs kg	35,200 16 000	31,500 14 290	26,900 12 200	23,400 10 610	20,600 9 340	18,300 8 300	16,300 7 390	14,900 6 760	13,600 6 200								
121 ft 36.9m	35,200 lbs – 64 ft 16 000 kg – 19.5m	lbs kg	35,200 16 000	32,000 14 520	27,400 12 430	23,900 10 840	21,000 9 530	18,700 8 480	16,600 7 500										

### Capacity

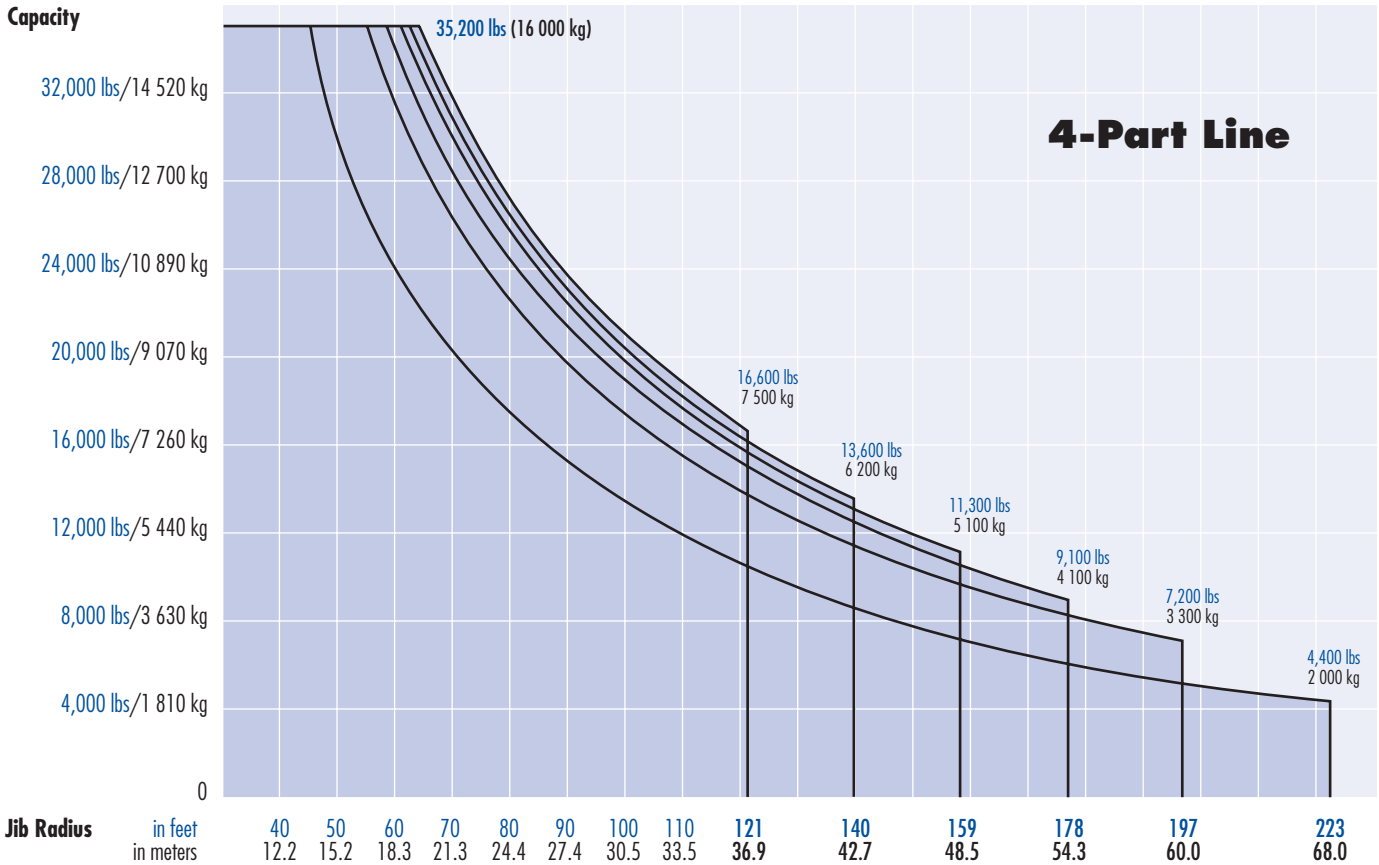

# SPECIFICATIONS

## Pecco Tower Crane Model SK 280-16

### Hoist Speed and Capacity

Hoist Unit	2-Part Line				
105 hp (78 kW) AC hoist unit 4-speed gearbox Remote-controlled gear shifting Eddy current brake	Gear	Capacity	Hoist Speed	Capacity	Hoist Speed
	1	up to 17,600 lbs	@ 110 fpm	up to 8 000 kg	@ 34 m/min
	2	up to 15,600 lbs	@ 178 fpm	up to 7 100 kg	@ 54 m/min
	3	up to 9,260 lbs	@ 282 fpm	up to 4 200 kg	@ 86 m/min
	4	up to 5,500 lbs	@ 440 fpm	up to 2 500 kg	@ 134 m/min
	4-Part Line				
	1	up to 35,200 lbs	@ 55 fpm	up to 16 000 kg	@ 17 m/min
	2	up to 31,200 lbs	@ 89 fpm	up to 14 200 kg	@ 27 m/min
3	up to 18,520 lbs	@ 141 fpm	up to 8 400 kg	@ 43 m/min	
4	up to 11,000 lbs	@ 220 fpm	up to 5 000 kg	@ 67 m/min	

<sup>2P180</sup>  
<sup>4P90</sup>

**NOTE!** Capacities and line speeds indicated will vary depending on the amount of hoist rope installed. This crane model may be equipped with a hoist unit other than that specified in the data above. To verify, check the serial number of the crane and refer to the Pecco SK 280-16 Operation Manual for additional information.

### Motor Information

Drive Unit	Horsepower	Kilowatts	Speed	
Trolley	12 hp	9 kW	0 - 320 fpm	0 - 96 m/min
Swing *	2 x 12 hp	2 x 9 kW	1.0 rpm	

\* **NOTE!** Jibs up to and including 143-ft (43.4m) hook reach require only one swing motor; jibs with 162-ft (49.2m) hook reach and longer require two swing motors.

### Power Requirements











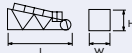
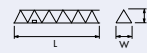

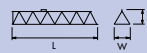

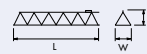

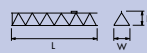

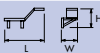
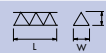

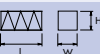



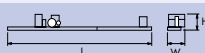

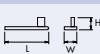



480 V — 3-phase — 60 Hz — 250 Amperes

Specifications subject to change without notice. For other configurations and specifications, contact Morrow Equipment.

**Morrow Equipment Co., L.L.C.**

# Component List

# Pecco SK 280-16

Description	Dimensions L x W x H	Weight	Description	Dimensions L x W x H	Weight
Tower Top	 30'-0" x 6'-8" x 7'-3" 9.14m x 2.03m x 2.21m	6,620 lbs 3 000 kg	Jib Section ①	 38'-9" x 6'-1" x 6'-2" 11.8m x 1.85m x 1.88m	6,600 lbs 3 000 kg
Turntable (Complete)	 9'-4" x 10'-0" x 10'-2" 2.84m x 3.03m x 3.1m	19,800 lbs 8 980 kg	Jib Section ②	 38'-9" x 6'-1" x 5'-11" 11.8m x 1.85m x 1.8m	4,400 lbs 2 000 kg
Turntable Upper Part <sup>1</sup>	 9'-4" x 6'-10" x 7'-0" 2.84m x 2.08m x 2.13m	10,200 lbs 4 625 kg	Jib Section ③	 38'-9" x 6'-1" x 5'-11" 11.8m x 1.85m x 1.8m	3,000 lbs 1 360 kg
Turntable Lower Part <sup>2</sup>	 8'-8" x 10'-0" x 3'-2" 2.65m x 3.03m x 0.97m	9,600 lbs 4 355 kg	Jib Section ④	 38'-9" x 6'-1" x 5'-11" 11.8m x 1.85m x 1.8m	3,000 lbs 1 360 kg
Operator's Cab	 5'-11" x 4'-3" x 7'-1" 1.8m x 1.3m x 2.16m	900 lbs 410 kg	Jib Section ⑤	 19'-9" x 6'-1" x 5'-11" 6.02m x 1.85m x 1.8m	1,600 lbs 725 kg
Cab Access Platform	 12'-8" x 5'-7" x 2'-9" 3.85m x 1.7m x 0.85m	1,000 lbs 455 kg	Jib Section ⑥	 19'-9" x 6'-1" x 5'-11" 6.02m x 1.85m x 1.8m	1,200 lbs 545 kg
Tower Section S35	 19'-5" x 7'-10" x 8'-0" 5.92m x 2.4m x 2.44m	8,900 lbs 4 040 kg	Jib Section ⑦	 26'-0" x 6'-1" x 5'-11" 7.9m x 1.85m x 1.8m	1,400 lbs 635 kg
Transition Section S60 to S35	 19'-5" x 7'-11" x 7'-11" 5.92m x 2.41m x 2.41m	9,930 lbs 4 500 kg	Jib Section ⑧	 9'-11" x 6'-4" x 7'-1" 3.02m x 1.93m x 2.16m	1,000 lbs 455 kg
Tower Section S60	 19'-5" x 7'-11" x 7'-11" 5.92m x 2.41m x 2.41m	9,930 lbs 4 500 kg	Jib Assembly Part 1 <sup>6</sup> for all Jib Assemblies	 ①② 76'-2" x 6'-1" x 6'-2" 23.2m x 1.85m x 1.88m	15,750 lbs 7 145 kg
Counterjib <sup>3</sup> (Complete)	 69'-3" x 9'-1" x 5'-11" 21.1m x 2.77m x 1.8m	20,220 lbs 9 170 kg	Jib Assembly Part 2 <sup>7</sup> 225-ft (68.6m)	 ③④⑤⑥⑦⑧ 149'-1" x 6'-4" x 7'-1" 45.4m x 1.93m x 2.16m	12,300 lbs 5 580 kg
Counterjib Section #1 (Inner)	 30'-8" x 6'-4" x 5'-5" 9.35m x 1.93m x 1.66m	6,000 lbs 2 720 kg	Jib Assembly Part 2 <sup>7</sup> 200-ft (60.9m)	 ③④⑤⑥⑧ 123'-9" x 6'-4" x 7'-1" 37.7m x 1.93m x 2.16m	10,900 lbs 4 945 kg
Counterjib Section #2 <sup>4</sup> (Outer)	 38'-7" x 9'-1" x 5'-11" 11.75m x 2.77m x 1.8m	14,220 lbs 6 450 kg	Jib Assembly Part 2 <sup>7</sup> 180-ft (55.0m)	 ③④⑤⑧ 104'-9" x 6'-4" x 7'-1" 31.9m x 1.93m x 2.16m	9,700 lbs 4 400 kg
Hoist Unit <sup>5</sup> (105 hp/78 kW)	 9'-2" x 8'-11" x 4'-7" 2.79m x 2.72m x 1.4m	10,220 lbs 4 635 kg	Jib Assembly Part 2 <sup>7</sup> 162-ft (49.2m)	 ③④⑧ 85'-9" x 6'-4" x 7'-1" 26.1m x 1.93m x 2.16m	7,300 lbs 3 310 kg
Counterweight Block A	 14'-8" x 7'-5" x 5'-1" 4.47m x 0.19m x 1.55m	6,800 lbs 3 085 kg	Jib Assembly Part 2 <sup>7</sup> 143-ft (43.4m)	 ③⑤⑧ 66'-8" x 6'-4" x 7'-1" 20.3m x 1.93m x 2.16m	5,900 lbs 2 675 kg
Counterweight Block B	 9'-5" x 5'-5" x 5'-1" 2.87m x 0.14m x 1.55m	3,200 lbs 1 450 kg	Jib Assembly Part 2 <sup>7</sup> 124-ft (37.6m)	 ③⑧ 47'-8" x 6'-4" x 7'-1" 14.5m x 1.93m x 2.16m	4,300 lbs 1 950 kg
2-Part Trolley (Outer)	 5'-7" x 7'-1" x 4'-2" 1.7m x 2.16m x 1.28m	850 lbs 385 kg	Top Climbing Unit with Hydraulics (S35)	 29'-3" x 11'-6" x 11'-6" 8.9m x 3.5m x 3.5m	24,750 lbs 11 230 kg
Hook Block	 2'-5" x 1'-1" x 5'-7" 0.74m x 0.33m x 1.69m	900 lbs 410 kg	Jib A-frame	 21'-7" x 5'-5" x 4'-8" 6.57m x 0.14m x 1.43m	800 lbs 360 kg

**NOTE!** Weights and dimensions are approximate. Scale components before lifting.

<sup>1</sup> Turntable Upper Part includes swing motors and slewing ring. Does not include slewing ring support and support frame.

<sup>2</sup> Turntable Lower Part includes slewing ring support and support frame. Does not include Upper Part, slewing ring and swing motors.

<sup>3</sup> Includes Counterjib Sections #1 and #2, 105 hp (78 kW) AC hoist unit with frame, electrical panels and handrails. Does not include wire rope.

<sup>4</sup> Counterjib Section #2 includes 105 hp (78 kW) AC hoist unit with frame, electrical panels and handrails. Does not include wire rope.

<sup>5</sup> Includes frame and electrical panels. Does not include wire rope.

<sup>6</sup> Jib Assembly Part 1 includes jib sections, pendant cables, jib A-frame, trolley drive unit, trolley wire rope, 2-part trolley (outer) and hook block. If 4-part application is used, weight increases by 1,750 lbs (795 kg) for additional trolley (inner) and hook block.

<sup>7</sup> Jib Assembly Part 2 includes jib sections and pendant cables.



**Morrow Equipment**  
C O M P A N Y, L. L. C.

3218 Pringle Road SE • P O Box 3306 • Salem, Oregon 97302-0306 USA  
Tel. 503.585.5721 • Fax. 503.363.1172 • www.morrowequipment.com

The American home of  
**LIEBHERR**

Atlanta, GA • Charlotte, NC • Chicago, IL • Denver, CO • Honolulu, HI • Houston, TX • Los Angeles, CA • Las Vegas, NV  
Millwood, NY • St. Louis, MO • San Francisco, CA • Dallas, TX • Seattle, WA • Miami, FL • Tampa, FL • Washington, DC  
Sydney, Australia • Wellington, New Zealand • Vancouver, BC, Canada • Toronto, ON, Canada • México DF, México