

Pecco SK 200

TOWER CRANE

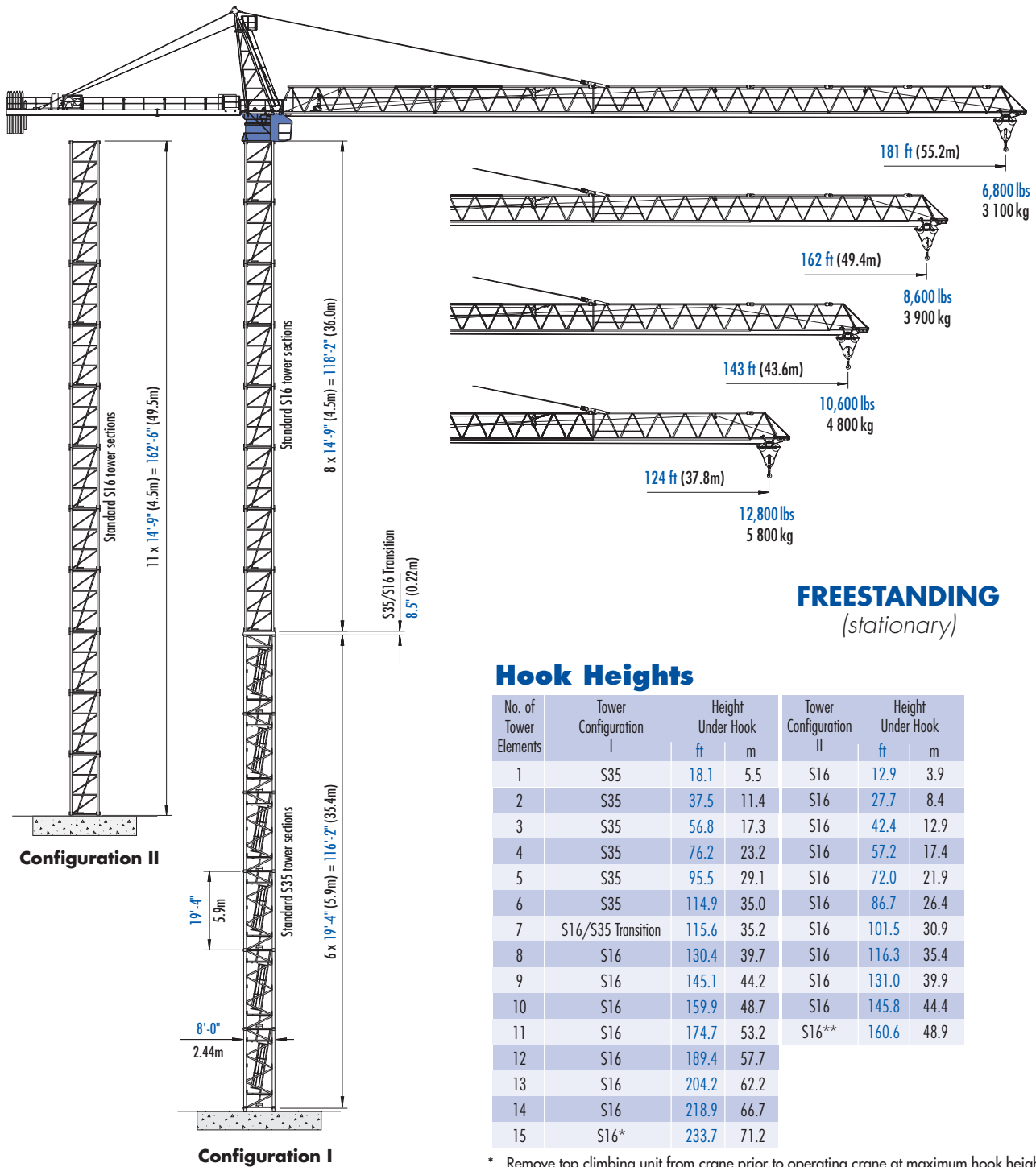

Hook Heights

No. of Tower Elements	Tower Configuration I	Height Under Hook		Tower Configuration II	Height Under Hook	
		ft	m		ft	m
1	S35	18.1	5.5	S16	12.9	3.9
2	S35	37.5	11.4	S16	27.7	8.4
3	S35	56.8	17.3	S16	42.4	12.9
4	S35	76.2	23.2	S16	57.2	17.4
5	S35	95.5	29.1	S16	72.0	21.9
6	S35	114.9	35.0	S16	86.7	26.4
7	S16/S35 Transition	115.6	35.2	S16	101.5	30.9
8	S16	130.4	39.7	S16	116.3	35.4
9	S16	145.1	44.2	S16	131.0	39.9
10	S16	159.9	48.7	S16	145.8	44.4
11	S16	174.7	53.2	S16**	160.6	48.9
12	S16	189.4	57.7			
13	S16	204.2	62.2			
14	S16	218.9	66.7			
15	S16*	233.7	71.2			

* Remove top climbing unit from crane prior to operating crane at maximum hook height.

** Lower top climbing unit to base of crane prior to operating crane at maximum hook height. Other tower combinations are possible. Contact Morrow Equipment for additional information.



Morrow Equipment

Configurations

Pecco SK 200

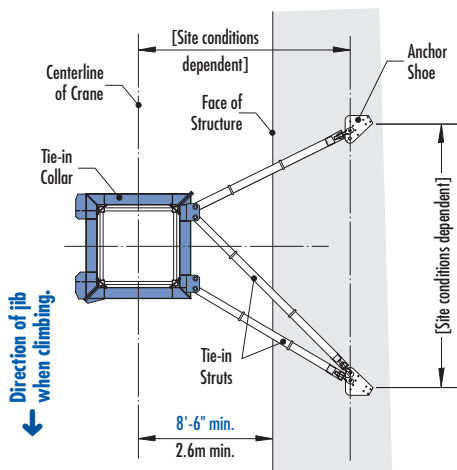

TIE-IN ASSEMBLY
(Plan View)

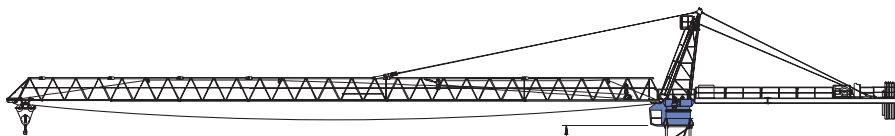

NOTE! If hook height exceeds 330 ft (100m), the number of tower sections above the uppermost tie-in location **MUST** be reduced by 1 tower section.

* Lower the top climbing unit to the uppermost tie-in prior to operating crane at maximum hook height.

Consult Morrow Equipment for specific information regarding dimensions, tie-in locations, reaction forces and slab openings.

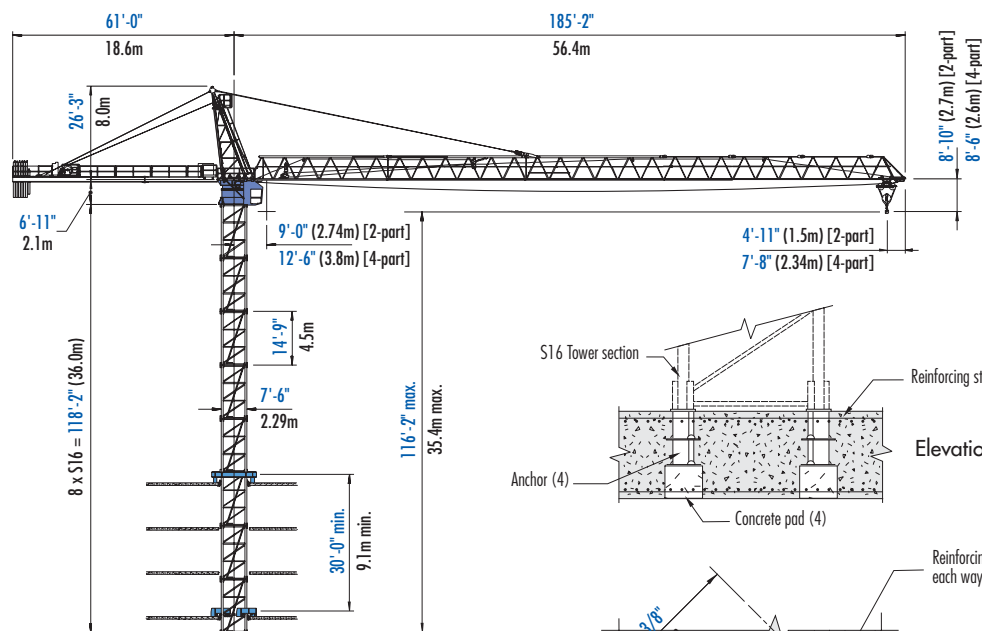

BOTTOM CLIMBING
with S16 Tower Sections
(Inside Structure)

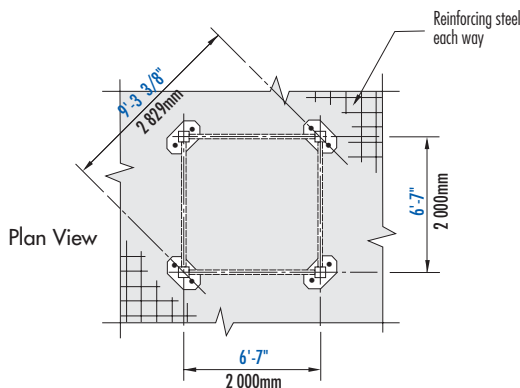
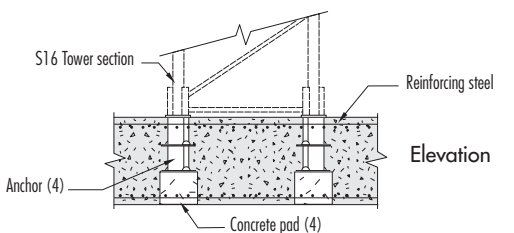

FOUNDATION DETAILS
with S16 Tower Sections
(Concrete Slab)

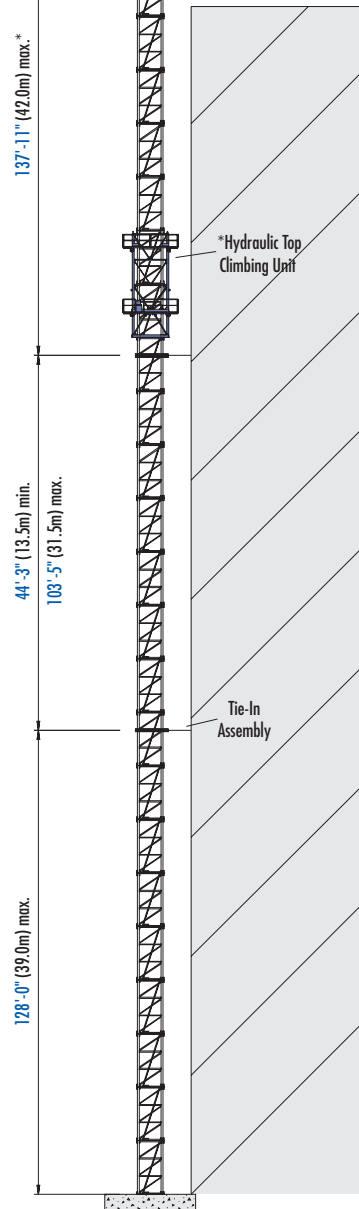

TOP CLIMBING
with S16 Tower Sections
(Tied to Structure)

IMPORTANT! Please consult crane's operation manual before erecting, operating and dismantling crane.

Radius and Capacities

Pecco Tower Crane Model SK 200

2-Part Line

Hook Radius	2-Part Line Max Capacity – Radius	ft m	100	105	110	115	120	124	130	135	143	145	150	155	162	165	170	175	181	
			30.5	32.0	33.5	35.1	36.6	37.8	39.6	41.1	43.6	44.2	45.7	47.2	49.4	50.3	51.8	53.3	55.2	
181 ft 55.2m	13,800 lbs – 100 ft 6 250 kg – 30.5m	lbs kg	13,800 6 250	13,400 6 080	12,300 5 580	11,600 5 260	11,000 4 990	10,700 4 850	10,100 4 580	9,700 4 400	9,000 4 080	8,800 3 990	8,400 3 810	8,200 3 720	7,800 3 540	7,600 3 450	7,300 3 310	7,100 3 220	6,800 3 100	
162 ft 49.4m	13,800 lbs – 108 ft 6 250 kg – 32.9m	lbs kg	13,800 6 250	13,800 6 250	13,300 6 030	12,700 5 760	12,100 5 490	11,700 5 310	11,000 4 990	10,600 4 810	9,900 4 490	9,700 4 400	9,300 4 220	9,000 4 080	8,600 3 900					
143 ft 43.6m	13,800 lbs – 110 ft 6 250 kg – 33.5m	lbs kg	13,800 6 250	13,800 6 250	13,800 6 250	13,500 6 120	12,800 5 810	12,500 5 670	11,700 5 310	11,300 5 130	10,600 4 800									
124 ft 37.8m	13,800 lbs – 115 ft 6 250 kg – 35.1m	lbs kg	13,800 6 250	13,800 6 250	13,800 6 250	13,800 6 250	13,200 5 990	12,800 5 800												

Capacity

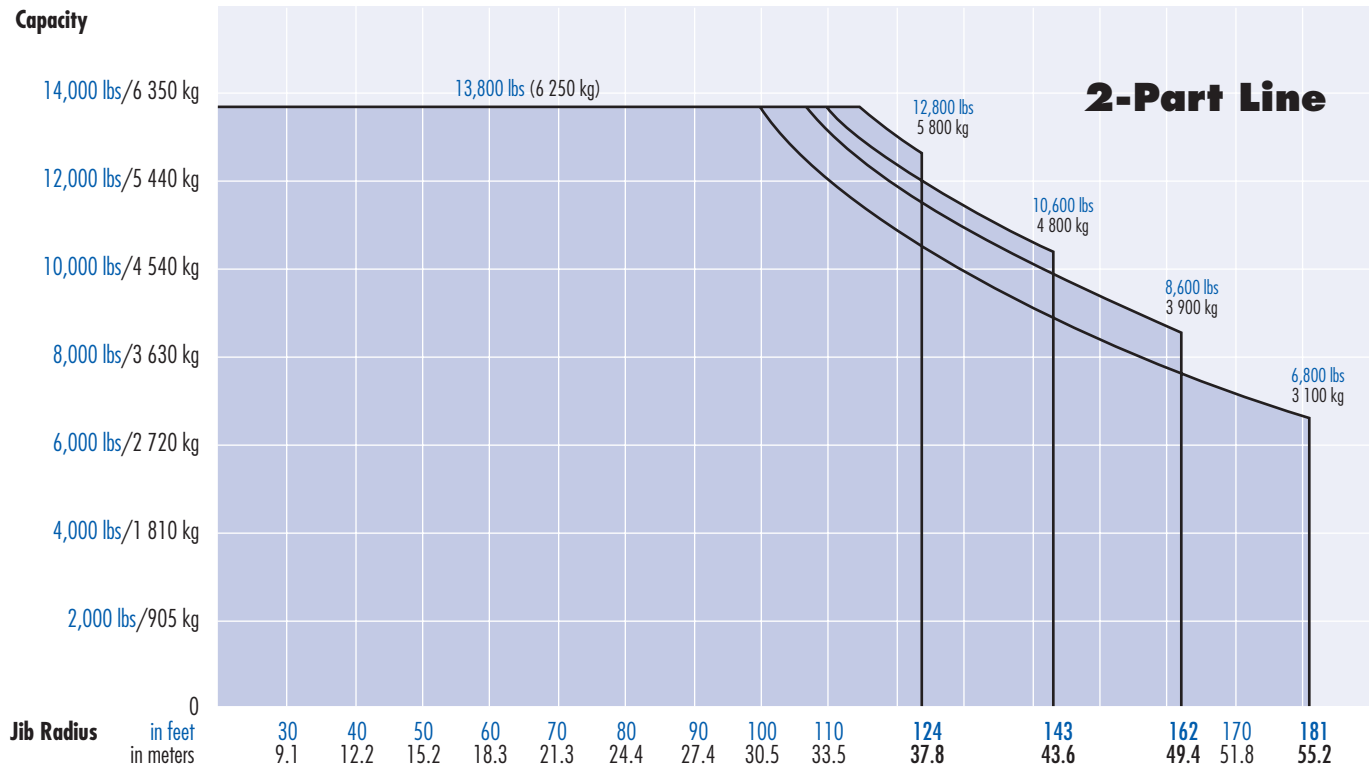

Radius and Capacities

Pecco Tower Crane Model SK 200

4-Part Line

Hook Radius	4-Part Line Max Capacity – Radius	ft m	20	30	40	51	60	70	80	90	100	110	121	130	140	150	159	170	178
			6.1	9.1	12.2	15.5	18.3	21.3	24.4	27.4	30.5	33.5	36.8	39.6	42.6	45.7	48.4	51.8	54.2
178 ft 54.2m	27,600 lbs – 51 ft 12 500 kg – 15.5m	lbs kg	27,600 12 500	27,600 12 500	27,600 12 500	27,600 12 500	23,300 10 570	19,200 8 710	16,200 7 350	14,000 6 350	12,200 5 530	10,800 4 900	9,800 4 450	8,800 3 990	8,000 3 630	7,300 3 310	6,700 3 040	6,200 2 810	5,700 2 600
159 ft 48.4m	27,600 lbs – 56 ft 12 500 kg – 17.0m	lbs kg	27,600 12 500	27,600 12 500	27,600 12 500	27,600 12 500	25,200 11 430	21,000 9 530	17,800 8 070	15,500 7 030	13,600 6 170	12,000 5 440	10,800 4 900	9,700 4 400	8,900 4 040	8,000 3 630	7,500 3 400		
140 ft 42.6m	27,600 lbs – 59 ft 12 500 kg – 18.0m	lbs kg	27,600 12 500	27,600 12 500	27,600 12 500	27,600 12 500	27,100 12 290	22,500 10 210	19,200 8 710	16,700 7 580	14,700 6 670	13,100 5 940	11,700 5 310	10,600 4 810	9,700 4 400				
121 ft 36.8m	27,600 lbs – 60 ft 12 500 kg – 18.3m	lbs kg	27,600 12 500	27,600 12 500	27,600 12 500	27,600 12 500	27,600 12 500	23,000 10 430	19,600 8 890	17,000 7 710	15,000 6 800	13,300 6 030	11,900 5 400						

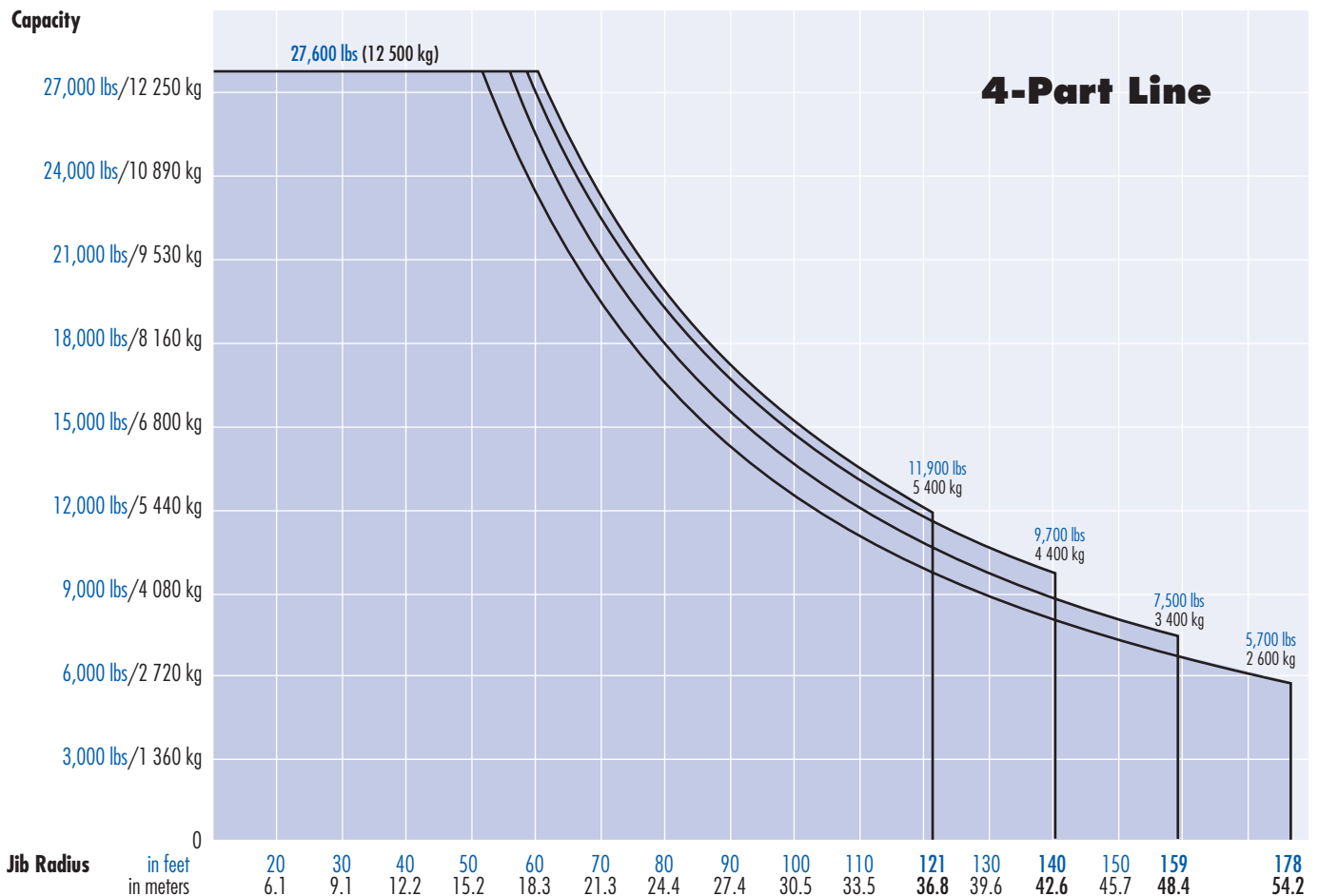

SPECIFICATIONS

Pecco Tower Crane Model SK 200

Hoist Speed and Capacity

Hoist Unit	2-Part Line				
105 hp (78 kW) AC hoist unit 4-speed gearbox Remote-controlled gear shifting Eddy current brake	Gear	Capacity	Line Speed	Capacity	Line Speed
	1	up to 13,800 lbs	@ 110 fpm	up to 6 250 kg	@ 34 m/min
	2	up to 13,800 lbs	@ 178 fpm	up to 6 250 kg	@ 54 m/min
	3	up to 9,260 lbs	@ 282 fpm	up to 4 200 kg	@ 86 m/min
	4	up to 5,500 lbs	@ 440 fpm	up to 2 500 kg	@ 134 m/min
	4-Part Line				
	1	up to 27,600 lbs	@ 55 fpm	up to 12 500 kg	@ 17 m/min
	2	up to 27,600 lbs	@ 89 fpm	up to 12 500 kg	@ 27 m/min
3	up to 18,520 lbs	@ 141 fpm	up to 8 400 kg	@ 43 m/min	
4	up to 11,000 lbs	@ 220 fpm	up to 5 000 kg	@ 67 m/min	

2P130
4P65

NOTE! Capacities and line speeds indicated will vary depending on the amount of hoist rope installed. This crane model may be equipped with a hoist unit other than that specified in the data above. To verify, check the serial number of the crane and refer to the Pecco SK 200 Operation Manual for additional information.

Motor Information

Drive Unit	Horsepower	Kilowatts	Speed	
Trolley (2-part line)	6.5 hp	4.8 kW	13 – 250 fpm	4 – 76 m/min
Trolley (4-part line)	6.5 hp	4.8 kW	6.5 – 125 fpm	2 – 38 m/min
Swing *	2 x 8 hp	2 x 6 kW	1.0 rpm	

* **NOTE!** Jib with hook reach of 124-ft (37.8m) requires only one swing motor; jibs with a hook reach of 143 ft (43.6m) and longer require two swing motors.











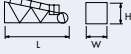

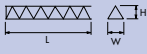

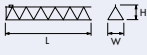

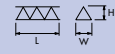

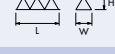
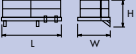

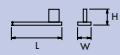

Power Requirements

480 Volts — 3-phase — 60-cycle — 250-Ampere service

Specifications subject to change without notice. For other configurations and specifications, contact Morrow Equipment.

Component List

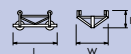
Pecco SK 200

Description	Dimensions L x W x H	Weight	Description	Dimensions L x W x H	Weight
Tower Top	 27'-4" x 6'-7" x 8'-5" 8.3m x 2.0m x 2.57m	3,800 lbs 1 725 kg	Jib Section ①	 38'-9" x 6'-1" x 7'-10" 11.8m x 1.86m x 2.4m	5,200 lbs 2 360 kg
Turntable (Complete) Upper & Lower Part	 9'-2" x 8'-5" x 8'-1" 2.79m x 2.57m x 2.47m	14,500 lbs 6 575 kg	Jib Section ②	 38'-9" x 6'-0" x 6'-9" 11.8m x 1.84m x 2.07m	3,600 lbs 1 630 kg
Turntable Upper Part ¹	 9'-2" x 8'-4" x 4'-6" 2.79m x 2.55m x 1.38m	6,900 lbs 3 130 kg	Jib Section ③	 38'-9" x 6'-0" x 7'-3" 11.8m x 1.84m x 2.2m	3,600 lbs 1 630 kg
Turntable Lower Part ²	 8'-6" x 8'-5" x 3'-7" 2.6m x 2.57m x 1.1m	7,600 lbs 3 450 kg	Jib Section ④	 19'-8" x 6'-0" x 6'-9" 6.0m x 1.84m x 2.07m	1,500 lbs 680 kg
Operator's Cab	 5'-4" x 3'-8" x 6'-7" 1.62m x 1.12m x 2.0m	900 lbs 410 kg	Jib Section ⑤	 19'-8" x 6'-0" x 6'-9" 6.0m x 1.84m x 2.07m	1,300 lbs 590 kg
Cab Access Platform	 8'-8" x 8'-3" x 5'-3" 2.65m x 2.52m x 1.6m	1,355 lbs 615 kg	Jib Section ⑥	 19'-8" x 6'-0" x 6'-9" 6.0m x 1.84m x 2.07m	1,000 lbs 455 kg
Counterjib ³ (Complete)	 57'-1" x 9'-1" x 5'-4" 17.4m x 2.76m x 1.62m	16,750 lbs 7 600 kg	Jib Section ⑦	 9'-10" x 6'-2" x 7'-11" 3.0m x 1.92m x 2.41m	900 lbs 410 kg
Counterjib Section #1 ⁴ (Inner)	 20'-8" x 6'-4" x 5'-0" 6.3m x 1.92m x 1.52m	2,800 lbs 1 270 kg	Jib Assembly ⁷ 181-ft (55.2m)	①②③④⑤⑥⑦	20,550 lbs 9 320 kg
Counterjib Section #2 ⁵ (Outer)	 36'-5" x 9'-1" x 5'-4" 11.1m x 2.76m x 1.62m	13,950 lbs 6 330 kg	Jib Assembly ⁷ 162-ft (49.4m)	①②③④⑤⑦	19,550 lbs 8 870 kg
Hoist Unit with Frame ⁶ (105 hp/78 kW)	 8'-4" x 5'-1" x 3'-6" 2.54m x 1.55m x 1.07m	9,600 lbs 4 355 kg	Jib Assembly ⁷ 143-ft (43.6m)	①②③④⑦	18,250 lbs 8 280 kg
Counterweight Block A	 10'-2" x 6" x 5'-1" 3.1m x 0.15m x 1.55m	3,750 lbs 1 700 kg	Jib Assembly ⁷ 124-ft (37.8m)	①②③⑦	16,750 lbs 7 600 kg
Counterweight Block B	 6'-11" x 5.5" x 5'-1" 2.1m x 0.14m x 1.55m	2,205 lbs 1 000 kg	Top Climbing Unit with Hydraulics (S16)	 23'-6" x 9'-9" x 9'-3" 7.16m x 2.97m x 2.82m	13,200 lbs 5 990 kg
Tower Section S16	 14'-11" x 7'-7" x 7'-7" 4.55m x 2.3m x 2.3m	5,500 lbs 2 500 kg	Tie-in Collar (S16)	 10'-11" x 1'-7" x 10'-2" 3.33m x 0.48m x 3.1m	3,300 lbs 1 500 kg
Tower Section S35	 19'-5" x 7'-10" x 8'-0" 5.92m x 2.4m x 2.44m	8,900 lbs 4 040 kg	2-Part Trolley (Outer)	 6'-7" x 6'-3" x 3'-2" 2.0m x 1.9m x 0.97m	850 lbs 385 kg
Transition Section S35/S16	 8'-1" x 7'-9" x 1'-1" 2.46m x 2.36m x 0.33m	1,610 lbs 730 kg	Hook Block	 2'-2" x 1'-0" x 3'-8" 0.66m x 0.3m x 1.12m	800 lbs 365 kg

NOTE: Weights and dimensions are approximate. Scale components before lifting.

- ¹ Turntable Upper Part includes swing motors. Does not include slewing ring and slewing ring support.
- ² Turntable Lower Part includes slewing ring and slewing ring support. Does not include Upper Part and swing motors.
- ³ Counterjib (Complete) includes Counterjib Section #1, Counterjib Section #2, 105 hp (78 kW) hoist unit with frame, electrical panel, handrails and suspension. Does not include wire rope.
- ⁴ Includes handrails, electrical panel. Does not include Counterjib Section #2.
- ⁵ Includes 105hp (78 kW) hoist unit with frame and suspension. Does not include Counterjib Section #1 and wire rope.
- ⁶ Does not include wire rope.
- ⁷ Jib Assemblies include jib sections, pendant cables, trolley drive unit, trolley wire rope, 2-part trolley (outer) and hook block. If 4-part application is used, weight increases by 1,650 lbs (750 kg) for additional trolley (inner) and hook block.



Morrow Equipment
C O M P A N Y, L. L. C.

3218 Pringle Road SE • P O Box 3306 • Salem, Oregon 97302-0306 USA
Tel. 503.585.5721 • Fax. 503.363.1172 • www.morrowequipment.com

The American home of
LIEBHERR

Atlanta, GA • Charlotte, NC • Chicago, IL • Denver, CO • Honolulu, HI • Houston, TX • Los Angeles, CA • Las Vegas, NV
Millwood, NY • St. Louis, MO • San Francisco, CA • Seattle, WA • Miami, FL • Tampa, FL • Washington, DC
Sydney, Australia • Wellington, New Zealand • Vancouver, BC, Canada • Toronto, ON, Canada • México DF, México